



IDT™ IN-DIE TAPPING



In-Die Tapping

	PAGE NUMBER
HY1024 Series	1
ME1024 Series	2
LP25M6 & LP516M8 Series	3
Accessories and Replacement Parts	
LP Extensions	4
Forming Taps	5
Pitch Inserts and Tapholders	6
Maximum Tapping Depth/Material Thickness	7
Lubrication – Tapping Fluid	8
Tapping Unit Lubrication Kits	8

In-Die Tapping Provides the Following Advantages and Benefits:

- ◆ Off-the-shelf ordering
- ◆ Eliminates secondary or off-line tapping operations; form and tap in the same operation
- ◆ Cam-operated ME tapping units designed to optimize performance in most mechanical presses
- ◆ Compact, low profile LP tapping units with no limitations on tapping angle; tap upwards, downwards or at any angle in between
- ◆ Provides misfeed protection against a no-hole condition
- ◆ Cold formed tapping results in high-strength threads without chip formation
- ◆ Easy to move from one die set to another
- ◆ No limitation with open die height or press stroke

HY1024 Series

for Hydraulic Presses

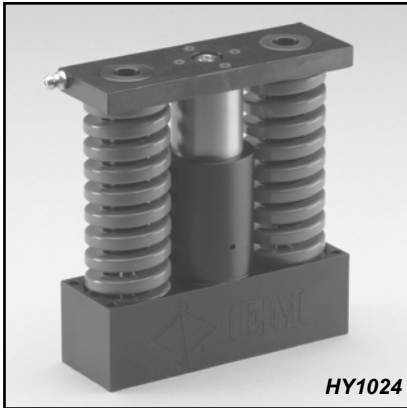

Product Features

The HY unit is the smallest and most compact of our In-Die Tapping tools. The HY1024 is an economical solution for tapping downward in a hydraulic press. Since the HY1024 is not cam actuated, the press controls the acceleration and tap speed. The HY1024 will tap sizes #0–#10 or up to M5. It typically runs at production rates between 60–100 strokes per minute (SPM) up to a maximum 200 SPM, depending on strip material, thickness, tap size and tap pitch.

By utilizing multiple tools in place of one special tapping tool, you can control flexibility in the stamping operation and greatly reduce downtime due to unscheduled maintenance.

NOTES:

- ◆ The HY1024 tapping tool generally is not recommended for use in a mechanical press. See the ME1024 or the LP25M6 for applications requiring use in a mechanical press.

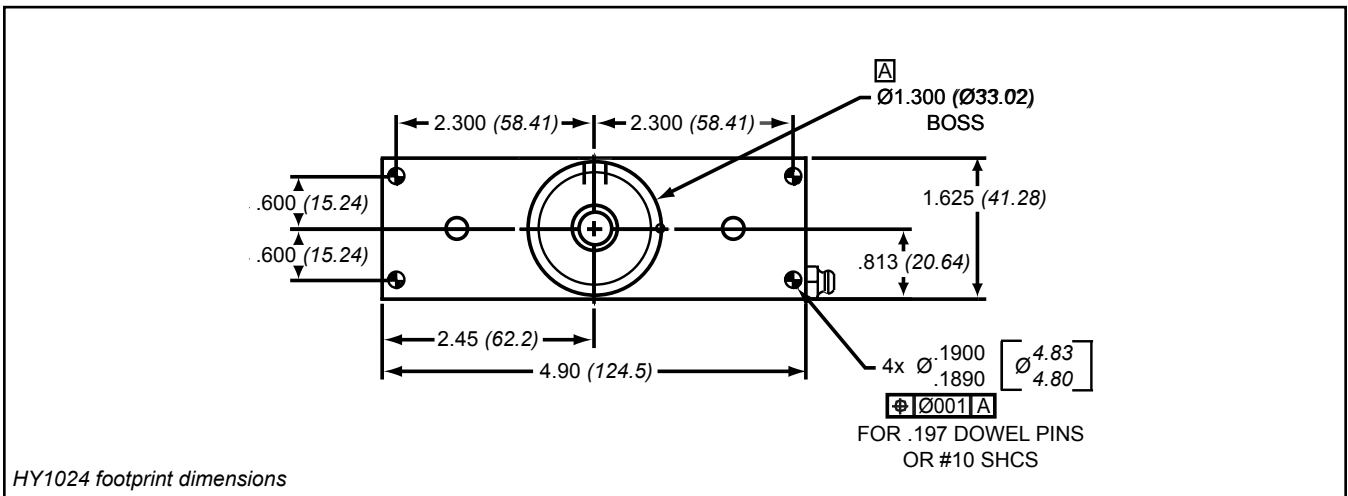
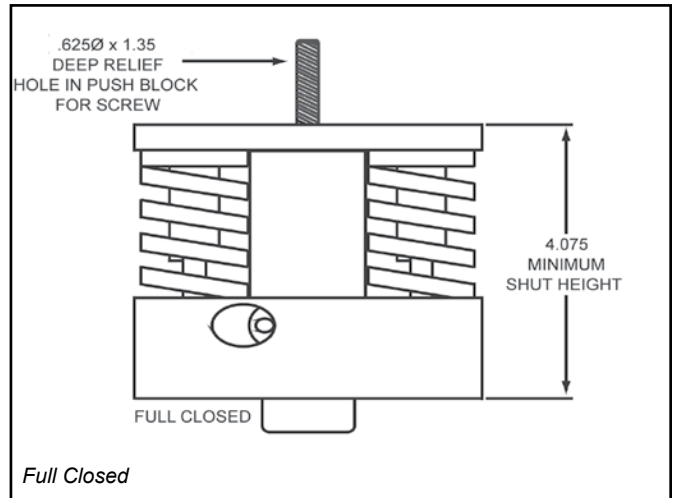
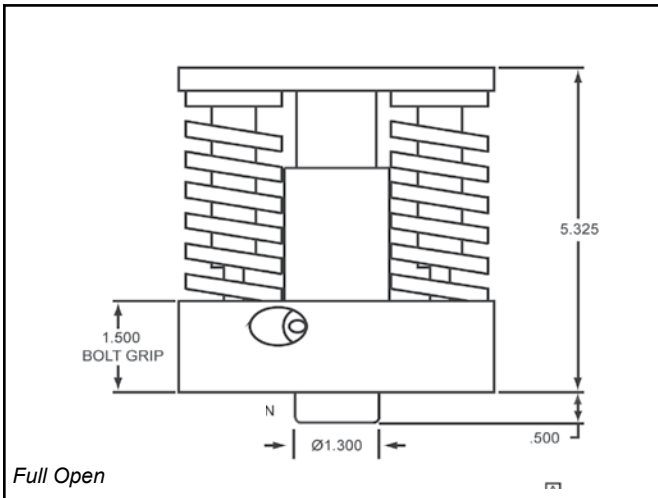

Notes: ◆ Tapping depth/maximum material thickness can be found on Page 7.

ME1024 Series

for Mechanical and Hydraulic Presses

Product Features

The ME1024 is a simple and compact In-Die Tapping tool for tapping downward in a mechanical or hydraulic press. The ME1024 utilizes a cam driver to control tool acceleration. The ME will tap sizes #0-#10 or up to M5 and typically runs at production rates between 60-100 strokes per minute (SPM) up to a maximum 200 SPM depending on strip material, thickness, tap size and tap pitch.

The cam driver is designed as a separate functional piece to maximize die design flexibility and transfer the inherent sinusoidal motion of the press into a rotary motion for tapping. The cam driver mounts easily on a punch plate or upper die shoe above the tapping tool. The cam driver is application specific and can be manufactured by using the free "Rapid TAP" CAD design software.

By utilizing multiple tools in place of one special tapping tool, you can control flexibility in the stamping operation and greatly reduce downtime due to unscheduled maintenance.

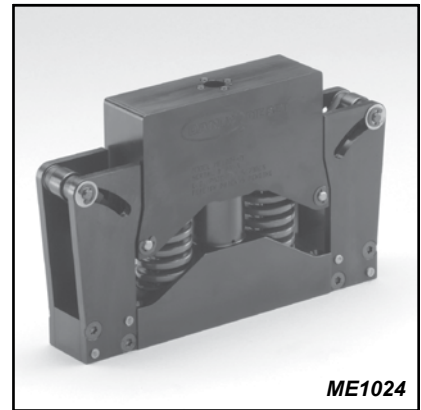

ME1024

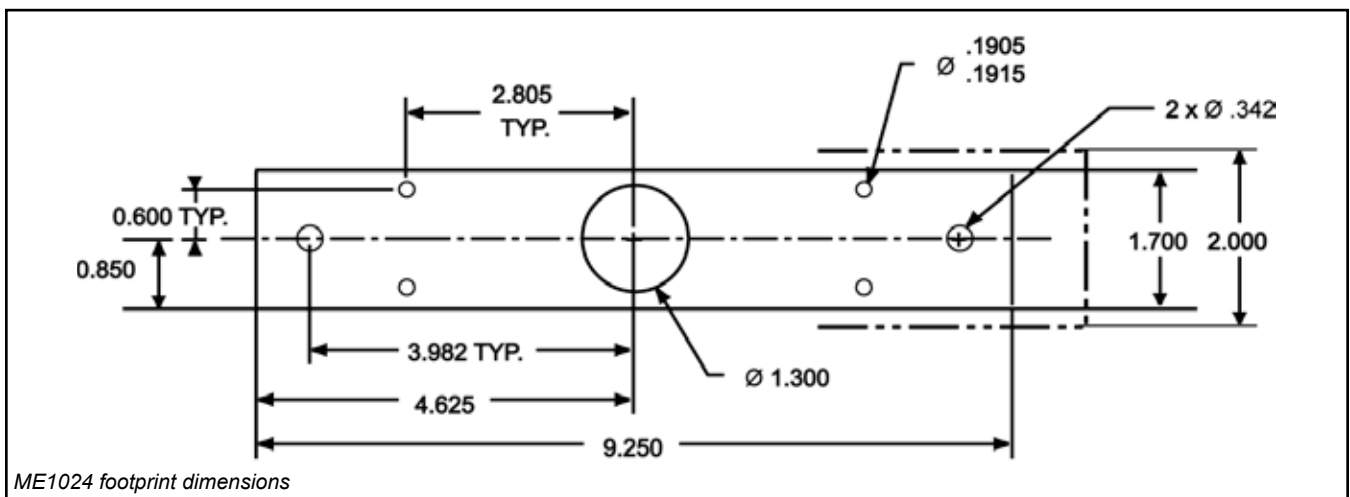
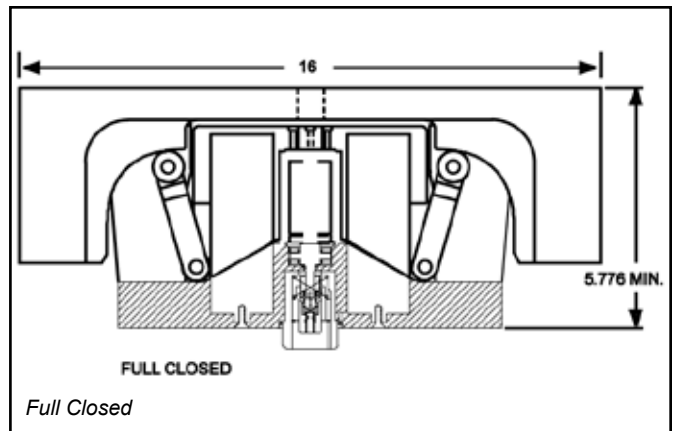
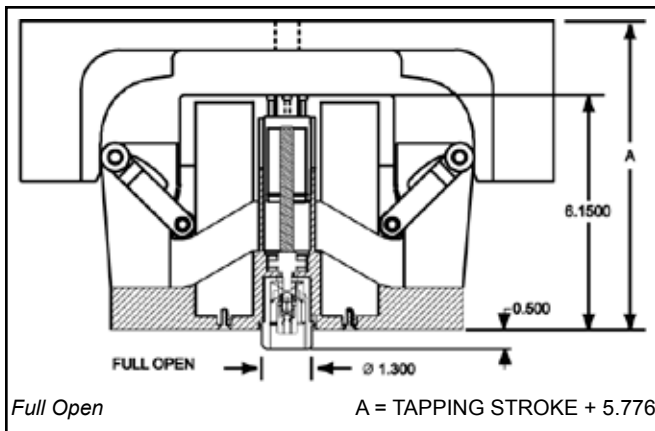

Notes: ♦ Tapping depth/maximum material thickness can be found on Page 7.
 ♦ All dimensions are in inches.

LP25M6 & LP516M8 Series

for Mechanical and Hydraulic Presses



LP25M6

Product Features

The LP is the most versatile of our mechanical In-Die Tapping tools with a simple and compact design capable of tapping in any direction. The LP units utilize a cam driver to control tool acceleration and tap speeds. The LP25M6 will tap size #0 – 1/4 or M6 and the LP516M8 will tap 1/4" – 5/16" or M8 while making either right or left-hand threads. The LP typically runs at production rates between 20–60 strokes per minute (SPM) up to a maximum of 100 SPM depending on strip material, thickness, tap size and tap pitch.

The cam driver is designed as a separate functional piece to maximize die design flexibility and transfer the inherent sinusoidal motion of the press into a rotary motion for tapping. The cam driver mounts easily on a punch plate on the upper die shoe above the tapping unit to provide the proper amount of tap acceleration and a positive return. The cam driver is application-specific and can be manufactured by using the free "Rapid TAP" CAD design software.

Multiple standard tools can be used in place of a special multi-head tapping tool to add flexibility and greatly reduce downtime.

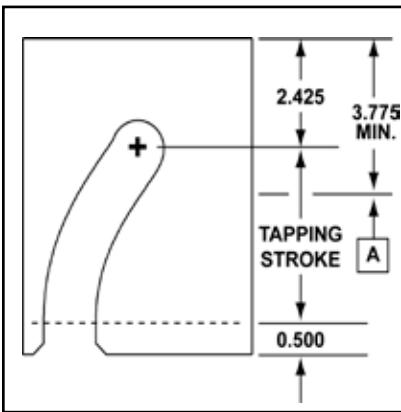

Important Note

The shut height from the upper shoe to the mounting surface cannot be less than 3.775", without engineered modifications. DO NOT manually alter the cam contour generated by the RapidTap software.

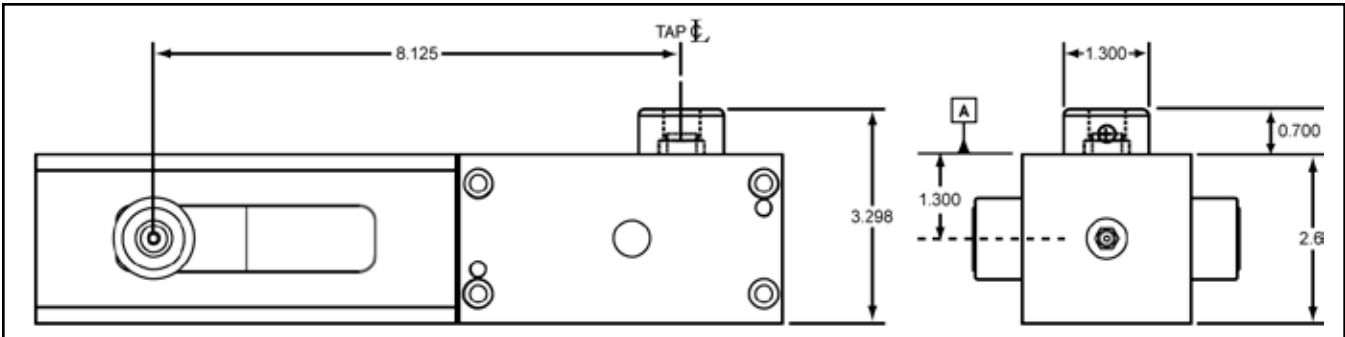

LP25M6 & LP516M8 footprint dimensions

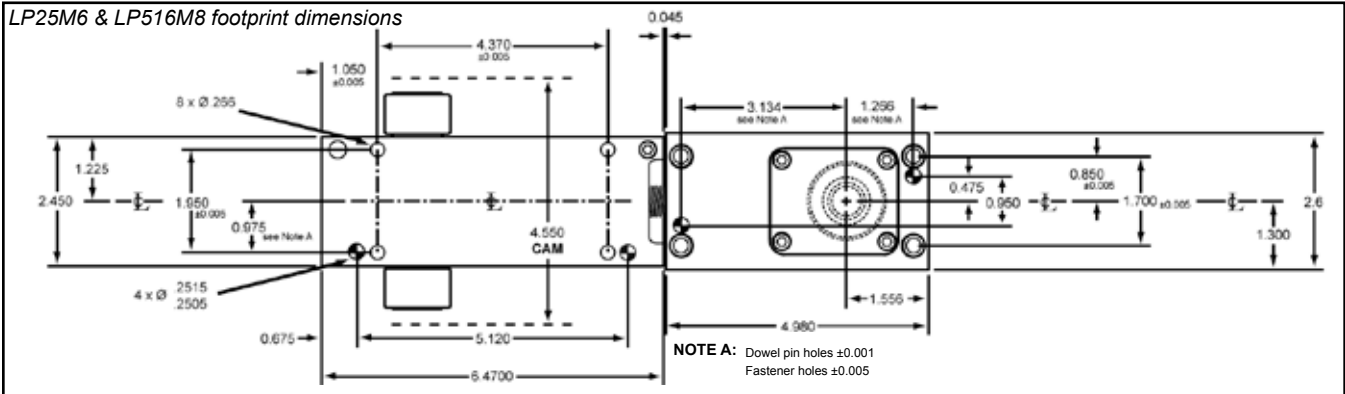

- Notes:**
- ◆ Footprint dimensions are identical for both units. However, performance variations exist between the two units. Consult the Rapid Tap software.
 - ◆ Tapping depth/maximum material thickness can be found on Page 7.
 - ◆ All dimensions are in inches.

Accessories and Replacement Parts

LP Extensions

Some applications require a wide strip width incorporating a tapped hole located a considerable distance away from the edge of the material. The LP integrates modular extensions with a standard tapping tool to provide flexibility in design and off-the-shelf components.

The Standard Extension provides over 9" of extra length while the Extra Long Extension provides over 19". All components are made from quality materials for maximum life and performance.

LP STANDARD EXTENSION

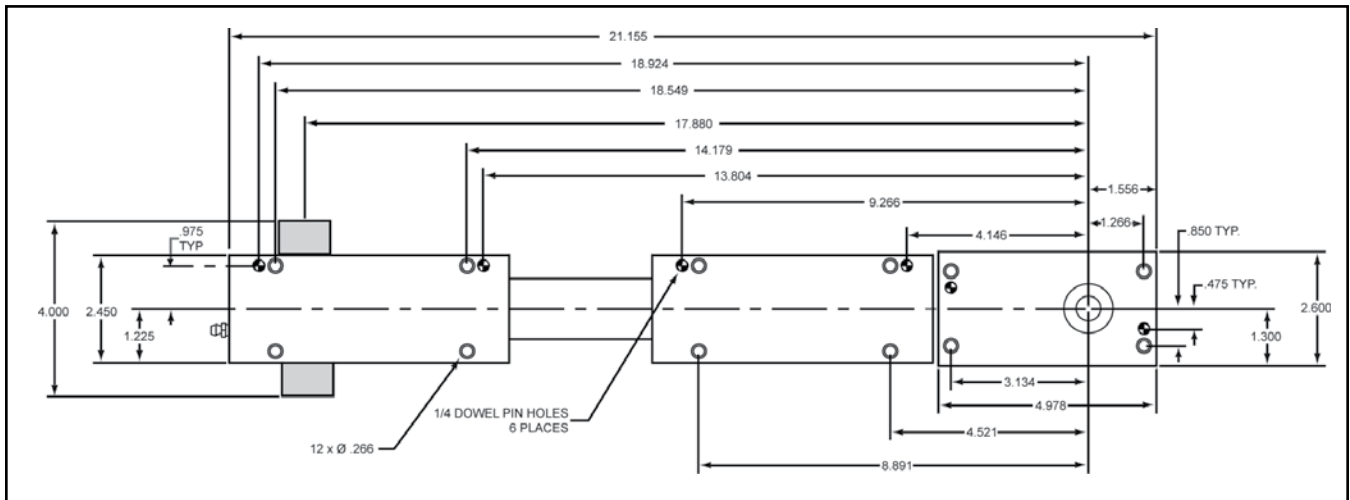

LP EXTRA LONG EXTENSION

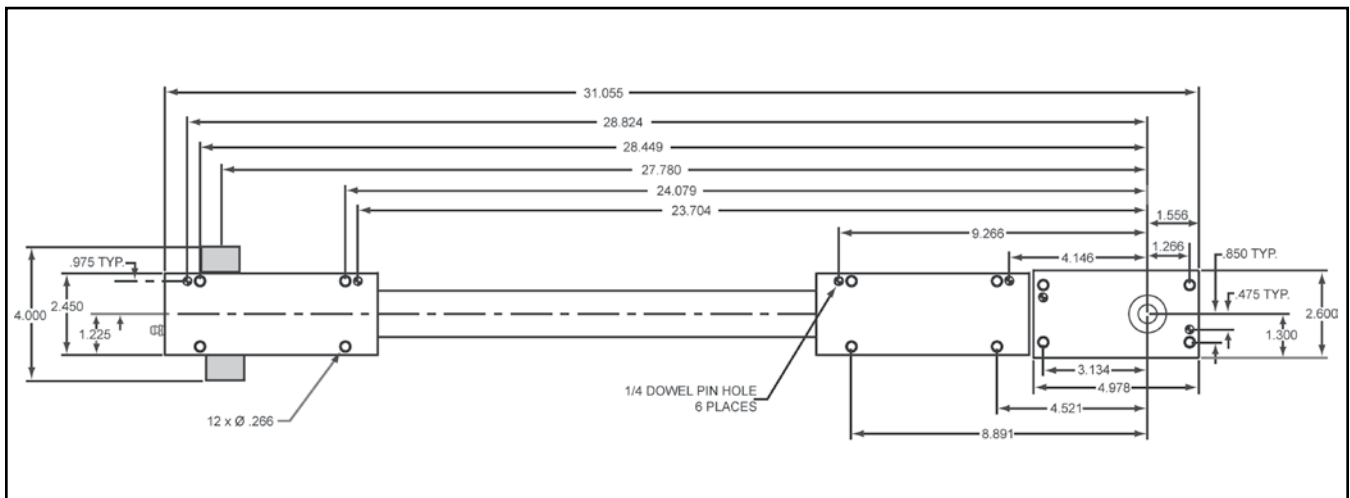

Notes: ♦ All dimensions are in inches.

Accessories and Replacement Parts



Forming Taps — Product Features

The special forming taps used in the in-die taping units are available in inch and metric standard sizes listed below. All forming taps are sold with a TiN coating as standard. Other coatings for special material applications are available on request. Forming taps provide a superior quality and finish of thread, with no chip formation.

INCH SIZES		
Part Number	Shank Size ¹	Tap Size & D Limit
R-006004	Small	2 - 56 – RH3
R-006008	Small	4 - 40 – RH5
R-006033	Small	4 - 40 – RH7
R-006010	Small	5 - 40 – RH5
R-006013	Small	6 - 40 – RH5
R-006009	Small	4 - 48 – RH5
R-006012	Small	6 - 32 – RH5
R-006031	Small	6 - 32 – RH7
R-006014	Small	8 - 32 – RH5
R-006030	Small	8 - 32 – RH7
R-006017	Small	10 - 32 – RH6
R-006032	Small	10 - 32 – RH8
R-006016	Small	10 - 24 – RH6
R-006023	Medium	12 - 28 – RH6
R-006022	Medium	12 - 24 – RH6
R-006021	Medium	1/4 - 28 – RH6
R-006090	Large	1/4 - 28 – RH6
R-006020	Medium	1/4 - 20 – RH6
R-006091	Large	1/4 - 20 – RH6
R-006092	Large	5/16 - 32 – RH6
R-006093	Large	5/16 - 24 – RH6
R-006094	Large	5/16 - 18 – RH7

METRIC SIZES		
Part Number	Shank Size ¹	Tap Size & D Limit
R-006042	Small	M2.0 x .40 D5
R-006044	Small	M2.5 x .45 D5
R-006045	Small	M3.0 x .50 D5
R-006046	Small	M3.5 x .60 D6
R-006047	Small	M4.0 x .70 D6
R-006049	Small	M5.0 x .80 D7
R-006050	Medium	M6.0 x 1.00 D8
R-006095	Large	M6.0 x 1.00 D8
R-006096	Large	M8.0 x 1.00 D8
R-006097	Large	M8.0 x 1.25 D8

Standard Stock Taps are TiN Coated

Special Tap Sizes, Pitches and Coatings are Available per Quotation

¹ Tap diameter shank size application:

- ◆ **Small** – 0 – #10 (M2 – M5) diameter taps: use in HY1024, ME1024, LP25M6
- ◆ **Medium** – #12, 1/4" and M6 diameter taps: use in LP25M6
- ◆ **Large** – 1/4" – 5/16" (M6 - M8) diameter taps: use in LP516M8

Accessories and Replacement Parts

Pitch Inserts/Tap Holders — Product Features

Pitch inserts are interchangeable components of the tapping operation and are specific to the pitch of the tapped hole. Each pitch insert contains a tap holder with a quick release ball-detent collar. Taps can be easily changed in most applications.

For applications which tap inside an embossment, a pitch insert extension can be made specific to your needs. Our engineering department will work with you to customize a pitch insert for your application.

INCH SIZES				
Pitch	Tap Holder Size ¹	Part Number for HY/ME1024	Part Number for LP25M6	Part Number for LP516M8
56	Small	R-002005	R-002024	—
48	Small	R-002006	R-002025	—
40	Small	R-002007	R-002026	—
32	Small	R-002008	R-002027	—
28	Small	R-002013	—	—
28	Medium	—	R-002031	—
28	Large	—	—	R-002112
10-24	Small	R-002010	R-002029	—
12-24	Medium	R-002014	R-002032	—
5/16-24	Large	—	—	R-002113
20	Medium	—	R-002030	—
20	Large	—	—	R-002114
18	Large	—	—	R-002115

METRIC SIZES				
Pitch	Tap Holder Size ¹	Part Number for HY/ME1024	Part Number for LP25M6	Part Number for LP516M8
0.40 mm	Small	R-002048	R-002068	—
0.45 mm	Small	R-002047	R-002067	—
0.50 mm	Small	R-002046	R-002066	—
0.60 mm	Small	R-002045	R-002065	—
0.70 mm	Small	R-002044	R-002064	—
0.80 mm	Small	R-002042	R-002062	—
1.00 mm	Medium	—	R-002060	—
1.00 mm	Large	—	—	R-002116
1.25 mm	Large	—	—	R-002117

Pitch inserts for non-standard sizes or pitches are by quotation.

¹ Tap diameter shank size application:

- ◆ **Small** – 0 – #10 (M2 – M5) diameter taps: use in HY1024, ME1024, LP25M6
- ◆ **Medium** – #12, ¼" and M6 diameter taps: use in LP25M6
- ◆ **Large** – ¼" – 5/16" (M6 - M8) diameter taps: use in LP516M8

Maximum Tapping Depth/Material Thickness

MAXIMUM MATERIAL THICKNESS (T) - INCH			
Size and Pitch	HY & ME 1024	LP25M6	LP516M8
2-64	0.080	—	—
2-56	0.091	0.180	—
3-56	0.091	0.180	—
3-48	0.106	0.220	—
4-48	0.106	0.220	—
4-40	0.128	0.240	—
5-44	0.116	0.270	—
5-40	0.128	0.270	—
6-40	0.128	0.270	—
6-32	0.159	0.260	—
8-36	0.142	0.250	—
8-32	0.159	0.250	—
10-32	0.159	0.250	—
10-24	0.213	0.230	—
12-28	—	0.230	—
12-24	—	0.220	—
1/4-28	—	0.220	0.300
1/4-20	—	0.190	0.290
5/16x32UN	—	—	0.260
5/16x24UN	—	—	0.340
5/16x18UN	—	—	0.275

MAXIMUM MATERIAL THICKNESS (T) - METRIC			
Size and Pitch	HY & ME 1024	LP25M6	LP516M8
M2 x .4	2.0	3.9	—
M2.5 x .45	2.2	4.5	—
M3 x .5	2.5	5.1	—
M3 x .6	3.0	6.3	—
M3.5 x .6	3.0	6.3	—
M4 x .7	3.5	6.6	—
M5 x .8	4.0	6.3	—
M5 x .9	4.5	5.9	—
M6 x 1.0	—	5.6	8.6
M8 x 1.0	—	—	8.6
M8 x 1.25	—	—	7.9

NOTE: Maximum material thickness (T) includes extrusion height and .020 inch (or 0.5mm) gap between the tip of the tap and the top of the material stock.

Lubrication – Tapping Fluid



Forming Tap Lubrication

Product Features

- ◆ Designed specifically for forming taps
- ◆ Faster tapping speeds
- ◆ Extends tap life

R-EDP00002	Pint Bottle
R-EDP00003	Case of 12 Pint Bottles
R-EDP00006	Case of 4 Gallon Bottles (case only)
R-EDP00004	5-Gallon Pail

Tapping Unit Lubrication Kits



R-003001

ME, HY Lubrication Kit R-003001

- ◆ Tube of red grease
- ◆ Pint of red oil
- ◆ Grease gun
- ◆ 18" flex extension for grease gun
- ◆ Small diameter hydraulic coupler
- ◆ 90° fitting for grease gun
- ◆ Straight extension for hydraulic coupler
- ◆ Oil can

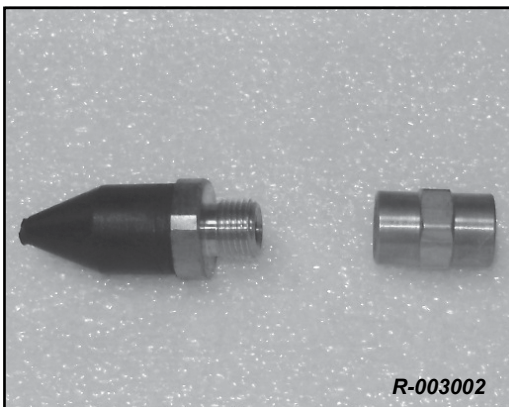

R-003002

** LP Lubrication Kit Model R-003002

Required with the ME, HY Lubrication kit for use with LP tools

- ◆ Rubber tip
- ◆ 1/8" coupling

In-Die Tapping Application Sheet

CUSTOMER INFORMATION

Date: _____

Company Name: _____

Contact Name: _____

Contact Phone: _____

Contact Email: _____

Address: _____

State: _____ ZIP: _____

PRESS INFORMATION

Press Type: Mechanical Hydraulic

Press Stroke: _____

Tapping Stroke: _____

Stripper Travel: _____

Desired Speed: _____

PART INFORMATION

Material Type: _____

Diameter & Pitch: _____

Number of Taps: _____

Hole Layout: _____

Tapping Direction (check one):

Top Down Bottom Up Sideways

Total Depth to Tap (T): _____

Clearance Gap (g): _____

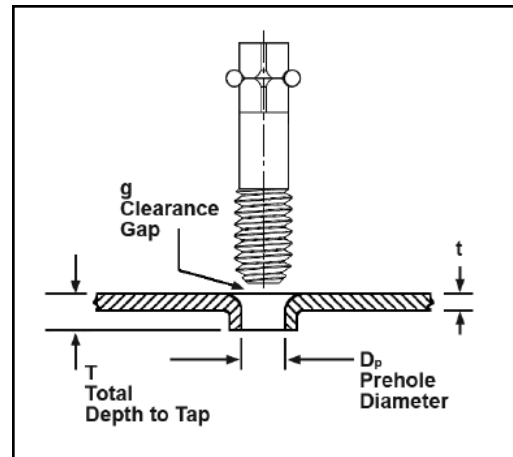

Part Print Sent? Yes No

Strip Layout Sent? Yes No

Part and layout prints are very helpful to ensure proper unit selection. Please send
TO THE ATTENTION OF: **In-Die Tapping Application Engineering Department**, at

FAX: 800-406-4410

or

EMAIL: info@anchorlamina.com

Commitment to Quality & Customer Satisfaction

Dayton Lamina is a leading manufacturer of tool, die and mold components for the metal-working and plastics industries. As a customer-focused, world-class supplier of choice, we provide the brands, product breadth, distribution network and technical support for all your metal forming needs.

Our goal is to give our customers the most innovative and value-added products and services.



DAYTON Lamina™

a MISUMI Group Company



Lamina® LEMPCO

*Dayton Lamina's line of Danly products is available only to North America.



Registered to ISO 9001



Registered to ISO 14001

www.daytonlamina.com